

**COMPACT
SHORT STROKE CYLINDERS
KSF-A SERIES Ø20- Ø100**

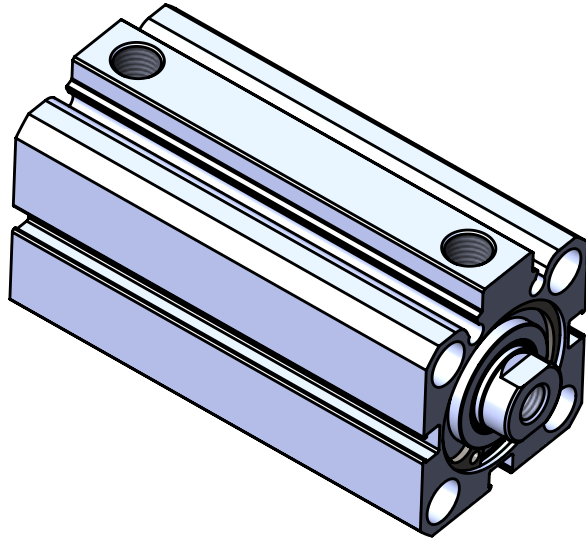

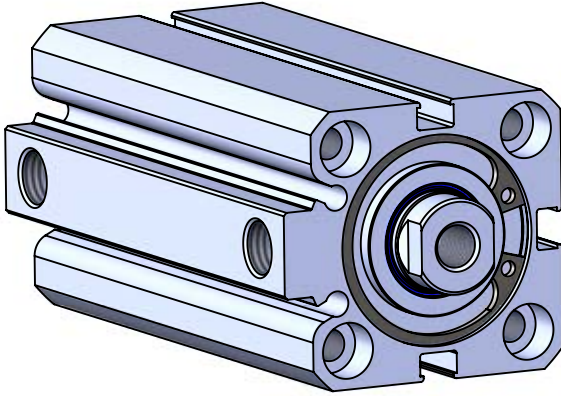

KSF -A SERIES
SHORT STROKE CYLINDER
Ø20 - Ø100

SHORT STROKE
WITH MAGNET AND FRONT SPRING

WITH SINGLE ACTING USAGE PROVIDES
MINIMUM AIR CONSUMPTION AND
EQUIPMENT COST

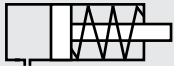

KSF: SHORT STROKE CYLINDERS
WITH SINGLE ACTING (SPRINGED
FROM FRONT)



KSF-A: SHORT STROKE MAGNETIC
CYLINDERS WITH SINGLE ACTING
(SPRINGED FROM FRONT)

Example of order:

KSF-A 032-025 M1
Product code Cylinder Ø Stroke Variants from
Standard System

VARIANTS FROM STANDART SYSTEM:

- R1 : Stainless Steel Piston Rod (SS 304-SS 316)
- R4 : Stainless Steel Nut for Piston Rod (SS 304)
- R5: Piston Rod as CK45 (Hard Chrome Plated)
- M1: Extended male Piston Rod Thread
- M3: Special Piston Rod Thread
- M4: Extended Piston Rod
- K1: Seals for Max. 150°C (Viton)
- K4: Piston Rod Seal Viton

Force:

Cylinder Ø mm	Rod Ø mm	Thrust and traction forces (6 Bar)	
		Thrust force (N)	Traction force (N)
20	10	145	9
25	12	270	13
32	16	397	16
40	16	654	23
50	20	1052	30
63	20	1732	35
80	25	2792	60
100	30	4386	100

Working Fluid:

Filtered and lubricated or filtered and
not lubricated air.

Operating Temperature Range:

Polyurethane (PU) : (-20°C) - (+80°C)
Viton (FKM) : (-30°C) - (+150°C)

Maximum work pressure:

10 Bar

**KSF-A SERIES
SHORT STROKE MAGNETIC SERIES**

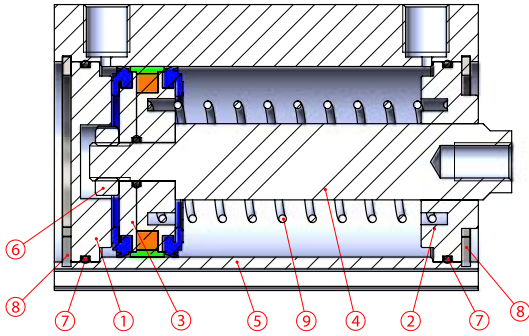

Stroke: Max. 50mm

**KSF SERIES
SHORT STROKE NO MAGNETIC SERIES**

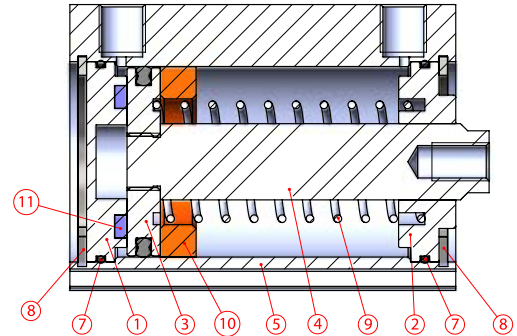

Stroke: Max. 50mm

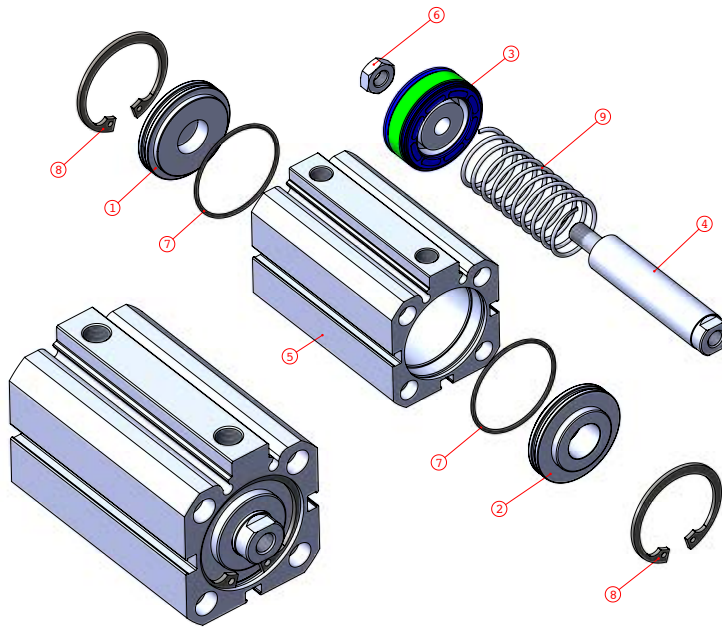

No	Material name	Characteristic		Pc.
		Magnetic	No Magnetic	
1	Rear Head	Bronze - 6082 Al. Eloxal Plated		1
2	Front Head	Bronze - 6082 Al. Eloxal Plated		1
3	Middle Piston	K58 PU + AL. + Polyacetal	6082 Al. + K62-K63 NBR	1
4	Piston Rod	X20Cr13 Hard Chrome Plated		1
5	Tube	Al Mg Si 0,5 + Eloxal Plated		1
6	Nut	Galvanized Steel		1
7	Head O-ring	NBR		2
8	Head Circlip	DIN 472 Steel		2
9	Spring	Galvanized Steel		1
10	POM			1
11	PU Bumper		PU 90	1

Not:
 Ø20 - Ø63 Front and Rear Head: Bronze
 Ø80- Ø100 Front and Rear Head: 6082 Al. + Eloxal Plated
 Ø20- Ø25 Magnetic Cylinder Middle Piston: Brass
 Ø32- Ø100 Magnetic Cylinder Middle Piston: K58
 Ø20- Ø100 No Magnetic Cylinder Middle Piston: 6082 Al. + K62-K63 NBR

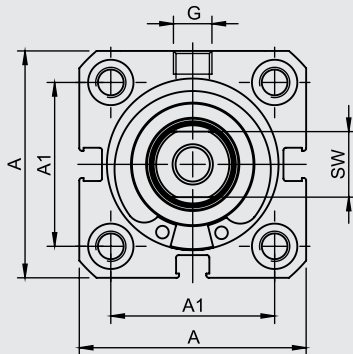
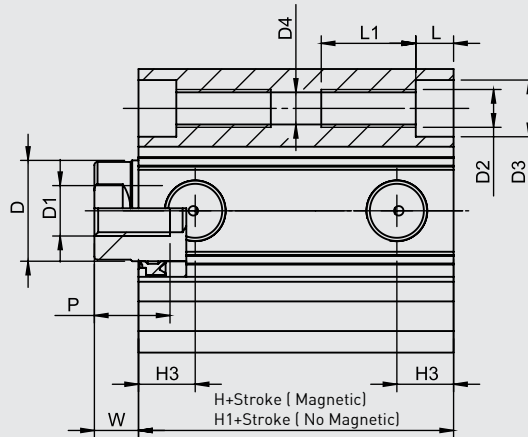

Ø 20 - Ø 25 CYLINDER

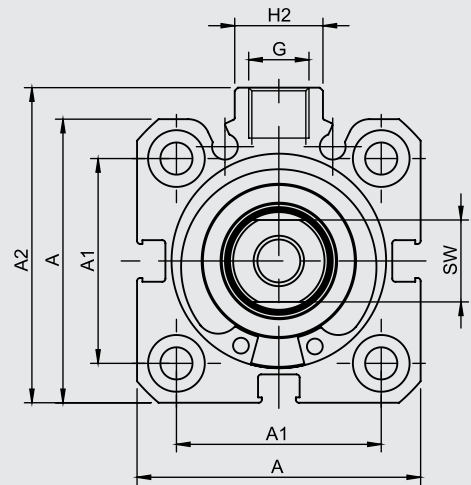

Ø 32 - Ø 100 CYLINDER

Cylinder Ø mm	A	A1	A2	D Ø	D1 Ø	D2 Ø	D3 Ø	D4 Ø	G	H	H1	H2	H3	L	L1	P	W	SW
20	36	22	-	10	M6	M5	7.5	4.15	M5	32	26	-	7.25	5	10	10	6	9
25	41	26	-	12	M6	M5	7.5	4.15	M5	33	27,5	-	7.25	5	10	10	6	10
32	45	32.5	50	16	M8	M6	9	5.1	1/8"	33	33	14	9	6	12	12	7	13
40	54	38	60	16	M8	M6	9	5.1	1/8"	39	38,5	15	11	6	12	12	7	13
50	64.5	46.5	70	20	M10	M8	11	6.7	1/8"	40.5	40	19	11.5	7	16	16	8	17
63	77.5	56.5	83	20	M10	M8	11	6.7	1/8"	46	41,5	19	12	7	16	16	8	17
80	96.5	72	102	25	M12	M10	13.5	8.6	1/8"	53.5	52,5	25	13.5	9	16	20	10	22
100	115	89	124	30	M12	M10	13.5	8.6	1/4"	62.5	61,5	25	15.5	9	16	20	10	27

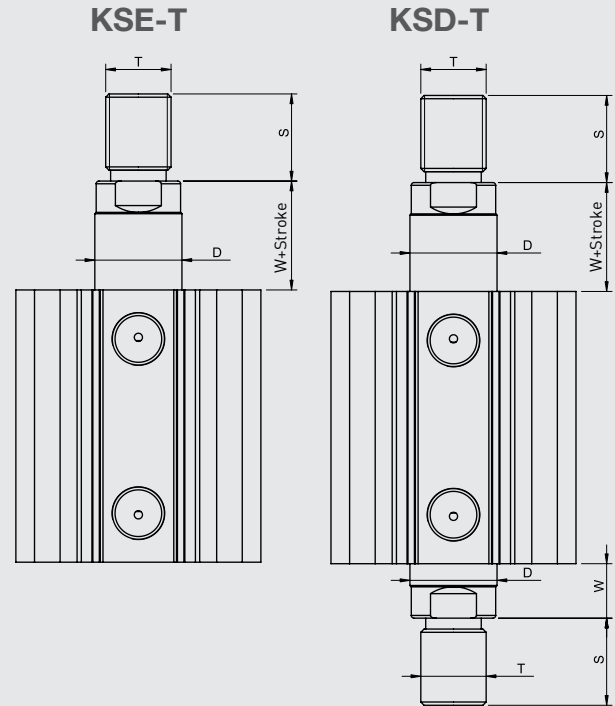
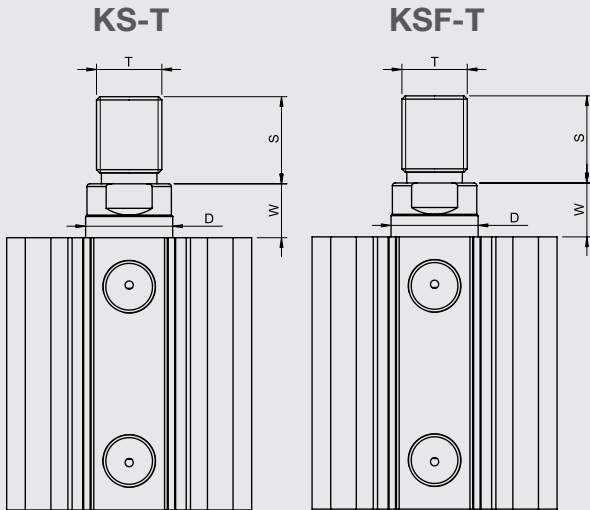
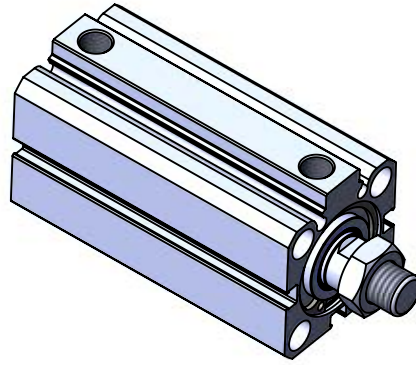

Cylinder type	Cylinder Ø mm	D	S	T	W
KS-KSF KSE-KSD	20	12	12	M8	6
	25	12	14	M10x1.25	6
	32	16	16	M12x1.25	7
	40	16	16	M12x1.25	7
	50	20	22	M16x1.5	8
	63	20	22	M16x1.5	8
	80	25	28	M20x1.5	10
	100	30	28	M20x1.5	10